

**NOTES:**

- FETS HAVE TYPE NUMBER 1511004 AND COME FROM DATE CODE 7349 AND 7442
- ARROW AT ROTARY CONTROLS SHOWS CLOCKWISE ROTATION.
- R36 AND R41 MOUNTED AT BOTTOM OF PCB
- R29 IS 470 K IN UNIT BUT LFO STALLED TILL VALUE WAS DECREASED TO 430K
- THIS SCHEMATIC WAS TRACED FROM A REAL UNIT. ALTHOUGH BELIEVED CORRECT IT MIGHT CONTAIN ERRORS OR DIFFERENCES TO OTHER UNITS.

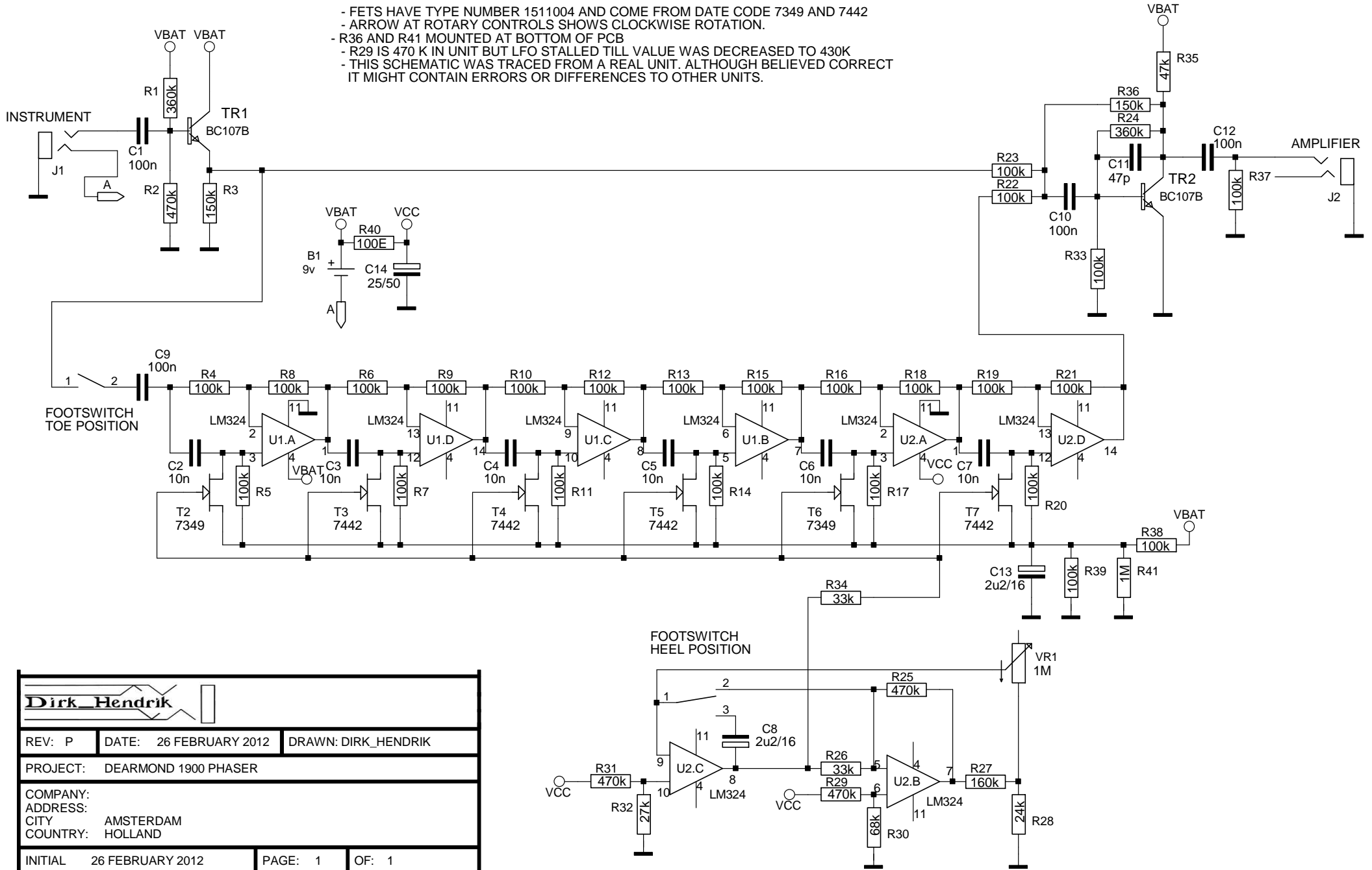

**Dirk Hendrik**

REV: P    DATE: 26 FEBRUARY 2012    DRAWN: DIRK\_HENDRIK

PROJECT: DEARMOND 1900 PHASER

COMPANY:  
 ADDRESS:  
 CITY: AMSTERDAM  
 COUNTRY: HOLLAND

INITIAL    26 FEBRUARY 2012    PAGE: 1    OF: 1

